

**USING  
SURESERVO™ WITH  
DIRECTLOGIC PLCs**

---



**In This Appendix ...**

Compatible *Direct*LOGIC PLCs and Modules . . . . .C-2  
Typical Connections to a DL05 PLC . . . . .C-4  
Typical Connections to an H0-CTRIO . . . . .C-5  
Typical Connections – Multiple Drives/Motors Through  
Communication . . . . .C-7  
Connecting *SureServo*™ to ADC Line Driver Encoders .  
. . . . .C-8  
Connecting *SureServo*™ to ADC Open-Collector  
Encoders . . . . .C-9

## Compatible *DirectLOGIC* PLCs and Modules

The following tables show which *DirectLOGIC* PLCs and modules can be used with *SureServo*™ servo systems.

<i>DirectLOGIC</i> PLC s/Modules for Use with <i>SureServo</i> Systems	
<b>DL05 PLCs</b>	
<b>D0-05AD</b>	DL05 CPU, 8 AC in / 6 DC out, 110/220VAC power supply. Inputs: 8 AC inputs, 90-120 VAC, 2 isolated commons. Outputs: 6 DC outputs, 6-27 VDC current sinking, 1.0A/pt. max., 1 common. 2 outputs are configurable for independent CW/CCW pulse train output or step and direction pulse output up to 7KHz (0.5A/pt.).
<b>D0-05DD</b>	DL05 CPU, 8 DC in / 6 DC out, 110/220VAC power supply. Inputs: 8 DC inputs, 12-24 VDC current sinking/sourcing, 2 isolated commons. Outputs: 6 DC outputs, 6-27 VDC current sinking, 1.0A/pt. max., 1 common. 2 outputs are configurable for independent CW/CCW pulse train output or step and direction pulse output up to 7KHz (0.5A/pt.) (not available when using high-speed inputs).
<b>D0-05DD-D</b>	DL05 CPU, 8 DC in / 6 DC out, 12/24VDC power supply. Inputs: 8 DC inputs, 12-24 VDC current sinking/sourcing, 2 isolated commons. Outputs: 6 DC outputs, 6-27 VDC current sinking, 1.0A/pt. max., 1 common. 2 outputs are configurable for independent CW/CCW pulse train output or step and direction pulse output up to 7KHz (0.5A/pt.) (not available when using high-speed inputs).
<b>DL06 PLCs</b>	
<b>D0-06DD1</b>	DL06 CPU, 20 DC in / 16 DC out, 110/220VAC power supply, with 0.3A 24VDC auxiliary device power supply. Inputs: 20 DC inputs, 12-24 VDC current sinking/sourcing, 5 isolated commons (4 inputs per common). Outputs: 16 DC outputs, 12-24 VDC current sinking, 1.0A/pt. max., 4 commons non-isolated (4 points per common). 2 outputs are configurable for independent CW/CCW pulse train output or step and direction pulse output up to 10KHz (0.5A/pt.) (not available when using high-speed inputs).
<b>D0-06DD1-D</b>	DL06 CPU, 20 DC in / 16 DC out, 12/24VDC power supply. Inputs: 20 DC inputs, 12-24 VDC current sinking/sourcing, 5 isolated commons (4 inputs per common). Outputs: 16 DC outputs, 12-24 VDC current sinking, 1.0A/pt. max., 4 commons non-isolated (4 points per common). 2 outputs are configurable for independent CW/CCW pulse train output or step and direction pulse output up to 10KHz (0.5A/pt.) (not available when using high-speed inputs).
<b>DL05/DL06 High Speed Counter I/O Module</b>	
<b>H0-CTRIO</b>	DL05/06 High Speed Counter I/O Interface Module, 4 DC sink/source inputs 9-30 VDC, 2 isolated sink/source DC outputs, 5-30 VDC, 1A per point. Inputs supported: 1 quadrature encoder counters up to 100KHz, or 2 single channel counters up to 100KHz, and 2 high speed discrete inputs for Reset, Inhibit, or Capture. Outputs supported: 2 independently configurable high speed discrete outputs or 1 channel pulse output control, 20Hz-25KHz per channel, pulse and direction or cw/ccw pulses.

<b>DirectLOGIC PLCs/Modules for Use with SureServo Systems (cont.)</b>	
<b>DL105 PLCs</b>	
<b>F1-130AD</b>	DL130 CPU, 10 AC in / 8 DC out, 110/220VAC Power Supply. Inputs: 10 AC inputs, 80-132 VAC, 3 isolated commons. Outputs: 8 DC outputs, 5-30VDC current sinking, 0.5A/pt. max, 3 internally connected commons. 3 internally connected commons. 2 outputs are configurable for independent CW/CCW pulse train output or step and direction pulse output up to 7KHz (@ 0.25A/pt. max).
<b>F1-130DD</b>	DL130 CPU, 10 DC in / 8 DC out, 110/220 VAC Power Supply. Inputs: 10 DC inputs, 12-24 VDC current sinking/sourcing, 3 isolated commons. Outputs: 8 DC outputs, 5-30VDC current sinking, 0.5A/pt. max, 3 internally connected commons. 2 outputs are configurable for independent CW/CCW pulse train output or step and direction pulse output up to 7KHz (@ 0.25A/pt. max) (not available when using high-speed inputs).
<b>F1-130DD-D</b>	DL130 CPU, 10 DC in / 8 DC out, 12/24VDC Power Supply. Inputs: 10 DC inputs, 12-24 VDC current sinking/sourcing, 3 isolated commons. Outputs: 8 DC outputs, 5-30VDC current sinking, 0.5A/pt. max, 3 internally connected commons. 2 outputs are configurable for independent CW/CCW pulse train output or step and direction pulse output up to 7KHz (@ 0.25A/pt. max) (not available when using high-speed inputs).
<b>DL205 High Speed Counter I/O Modules</b>	
<b>H2-CTRIO *</b>	DL205 High Speed Counter I/O Interface Module, 8 DC sink/source inputs 9-30VDC, 4 isolated sink/source DC outputs, 5-30VDC, 1A per point. Inputs supported: 2 quadrature encoder counters up to 100KHz, or 4 single channel counters up to 100KHz, and 4 high speed discrete inputs for Reset, Inhibit, or Capture. Outputs supported: 4 independently configurable high speed discrete outputs or 2 channels pulse output control, 20Hz-25KHz per channel, pulse and direction or cw/ccw pulses.
<b>D2-CTRINT</b>	Counter Interface Module, 4 isolated DC inputs, 1 pulse train output (cw) or 2 pulse train outputs (cw,ccw) with DC input restrictions, accepts two up-counters when used with D2-240 or D2-250(-1) (one only with D2-230), or one up/down counter. (not available when using high-speed inputs).
<b>Terminator I/O High Speed Counter I/O Module</b>	
<b>T1H-CTRIO *</b>	Terminator I/O High Speed Counter I/O Interface Module, 8 DC sink/source inputs 9-30VDC, 4 isolated sink/source DC outputs, 5-30VDC, 1A per point. Inputs supported: 2 quadrature encoder counters up to 100KHz, or 4 single channel counters up to 100KHz, and 4 high speed discrete inputs for Reset, Inhibit, or Capture. Outputs supported: 4 independently configurable high speed discrete outputs or 2 channels pulse output control, 20Hz-25KHz per channel, pulse and direction or cw/ccw pulses. (Use with T1K-16B or T1K-16B-1 terminal base.)
<b>DL405 High Speed Counter I/O Module</b>	
<b>H4-CTRIO</b>	DL405 High Speed Counter I/O Interface Module, 8 DC sink/source inputs 9-30VDC, 4 isolated sink/source DC outputs, 5-30VDC, 1A per point. Inputs supported: 2 quadrature encoder counters up to 100KHz, or 4 single channel counters up to 100KHz, and 4 high speed discrete inputs for Reset, Inhibit, or Capture. Outputs supported: 4 independently configurable high speed discrete outputs or 2 channels pulse output control, 20Hz-25KHz per channel, pulse and direction or cw/ccw pulses.
<b>* Note: The H2-CTRIO and T1H-CTRIO High Speed Counter I/O Interface Modules can also be used to control the SureServo Servo System in PC-Based Control systems with Think &amp; Do/Studio or with our embedded WinPLC/EBC module plugged into the CPU slot of the DL205 base.</b>	

## Typical Connections to a DL05 PLC

The following wiring diagram shows typical connections between the SureServo™ Servo System components and a DirectLOGIC DL05 PLC. Refer to the DL05 Micro PLC User Manual, p/n D0-USER-M, Chapter 3: High-Speed Input and Pulse Output Features, for detailed programming instructions when using the PLC for the Mode 30: Pulse Output function.

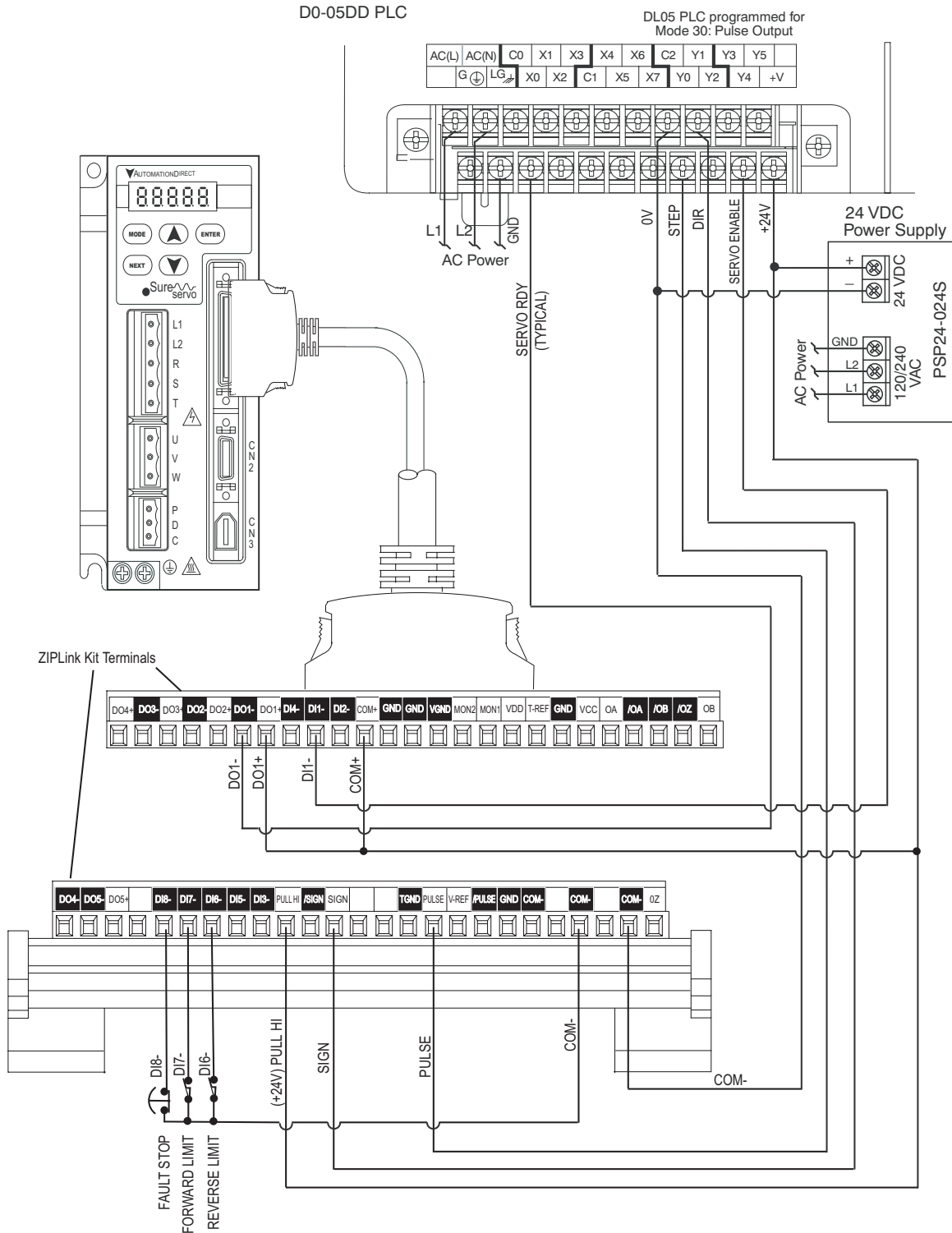

# Typical Connections to an H0-CTRIO

The following wiring diagram shows typical connections between the SureServo™ Servo System components and a DirectLOGIC H0-CTRIO High Speed Counter I/O Interface Module installed in either a DL05 or DL06 PLC option slot. Refer to the CTRIO High-Speed Counter Module User Manual, p/n HX-CTRIO-M, for detailed programming instructions when using the H0-CTRIO module.

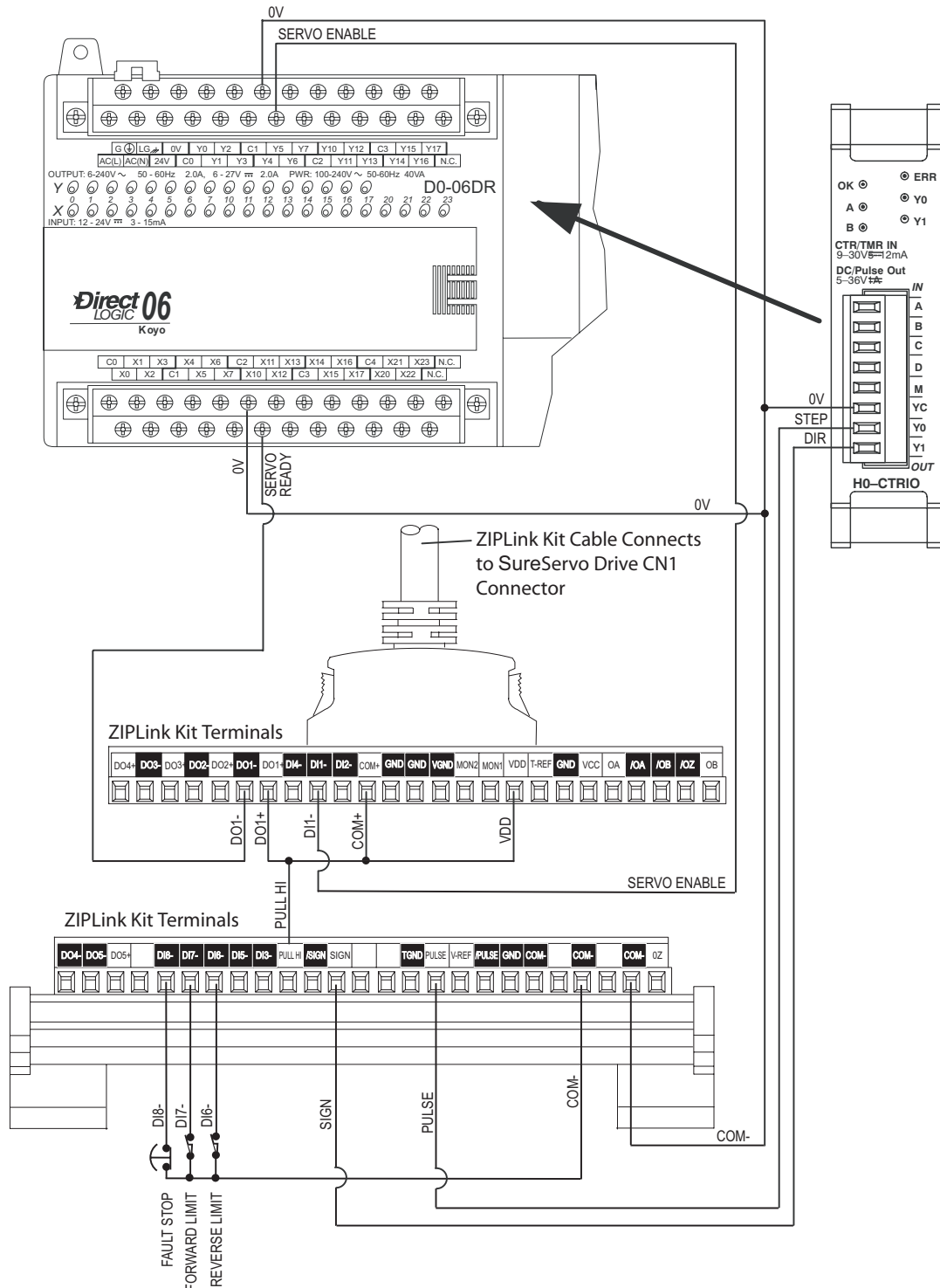

The following wiring diagram shows typical connections between the SureServo™ servo components and a DirectLogic DL06 PLC. Although this example is a PLC, any Modbus master controller would work in this control scheme.

Refer to the DL06 programming manual for detailed programming instructions and examples using Port 2 of the DL06 for Modbus communications. Modbus register addresses can be found in Chapter 6 of this manual.

Below find a few quick-start tips when using this control method:

- The communication parameters P3-01 (Baud rate) and P3-02 ( protocol) should match in all the devices and the multidrop network. Each device on this network **MUST** have a unique Modbus identifier: Set P3-00 to a unique address. P3-05 (RS communication type) must also be set the same in each servo system.
- To use RS485 communications, simply jumper the TX- and RX- signals together as well as the TX+ and RX+ signals and set parameter P3-05 = 1.
- If your application needs to change speeds, positions, ramps, etc. frequently, P2-30 should be set to 5 to prevent excessive writes to flash memory. As with any EE-type memory, there is a finite number of times the hardware can be written to before it will become damaged and fail. By setting the parameter to 5, the drive uses the new values that are written but they are not set to flash memory, thereby not prematurely damaging the drive.



---

***NOTE: The value in P2-30 is NOT stored in flash memory and MUST be set each time the drive is powered up (default is zero).***

---

# Typical Connections – Multiple Drives/Motors Through Communication

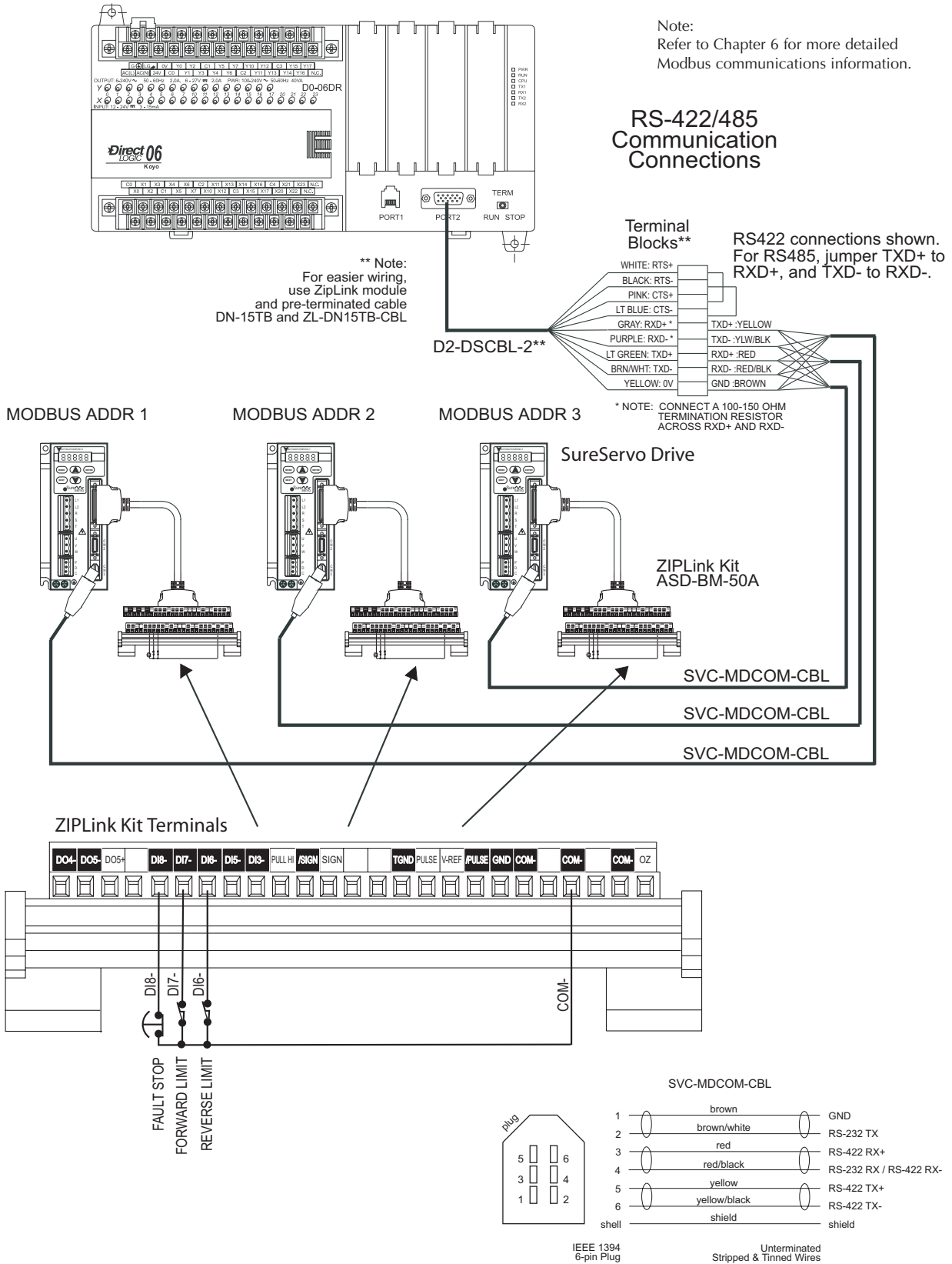



# Connecting SureServo™ to ADC Open-Collector Encoders

## ADC Model TRD-Sxxx-BD Open-Collector Encoder Connections

